

MF110-21

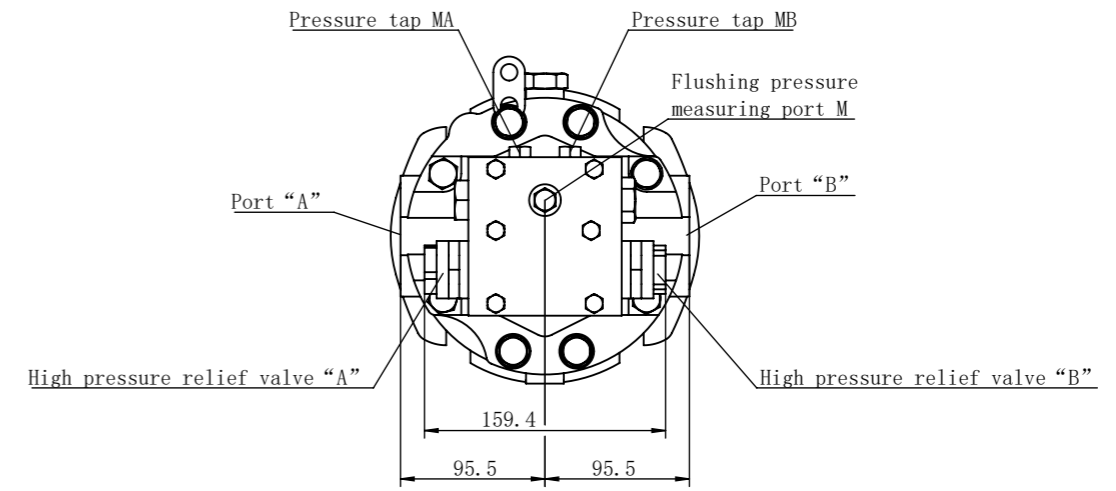

technical requirement	
Minimum speed	500r/min
maximum speed	2600r/min
Rated working pressure	30Mpa

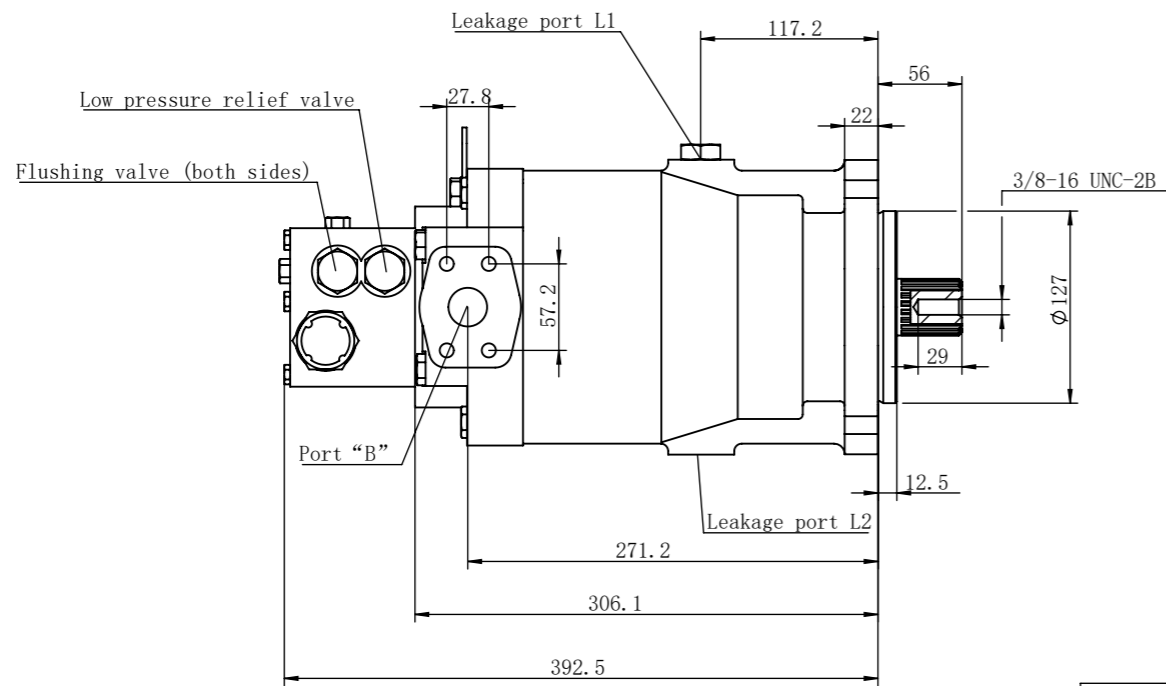
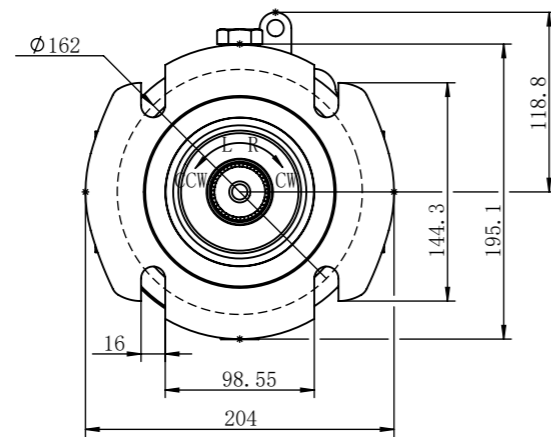

Motor shaft rotation direction		
	Port A	Port B
Clockwise CW	out	enter
Counterclockwise CCW	enter	out

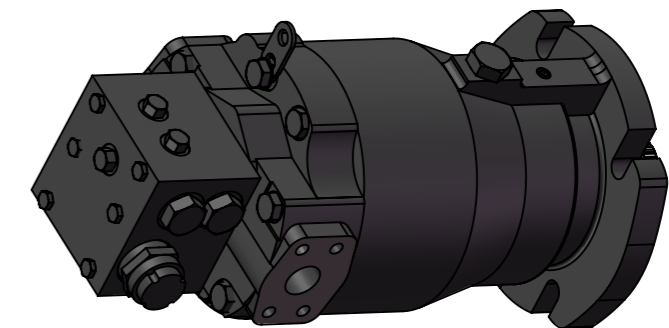

Propeller shaft spline				Conical axis		Displacement 110 ml/r	Ports A, B		Ports L1, L2 7/8-14 UNF-2B	Port M 7/16-20 UNF-2B	Port MA and MB	High pressure relief valve A, B 35Mpa 42Mpa
Teeth	Z	21	23	Lock nut 1-20 UNEF-2B wrench: 38	3/8-16 UNC-2B Depth: 25mm							
Radial pitch	M	16/32	16/32		A6 mm[in]		A7 mm[in]					
Pressure angle	a	30°	30°		52.4		26.2					
Dividing circle diameter	D	Ø33.34	Ø36.5									

	Product model		MF110-21
	Product name		Closed axial piston motor
	Date	Weight (kg)	Proportion
	49	1:5	